

compressors

Electrical Schematic

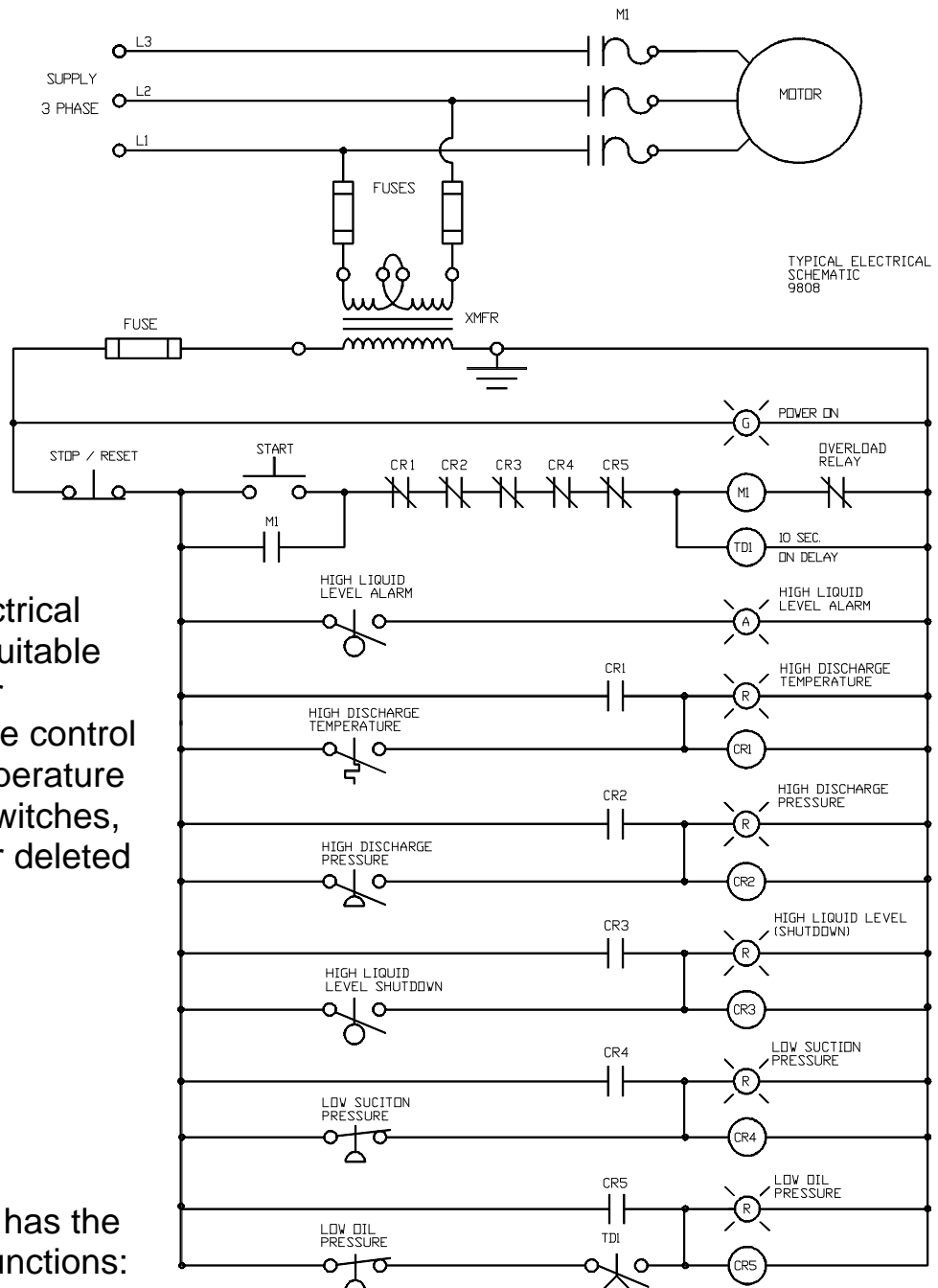

This generalized electrical wiring schematic is suitable for many compressor applications. Two line control devices such as temperature switches, pressure switches, etc. may be added or deleted as needed.

The circuit as shown has the following features / functions:

- 3 phase cross-line motor starter (M1)
- Control circuit transformer (XMFR)
- Start / Stop pushbutton control
- Power On light
- High Trap Liquid Level Alarm with light.
- High Discharge Temperature Shutdown with light.
- High Discharge Pressure Shutdown with light.
- High Trap Liquid Level Shutdown with light.
- Low Suction Pressure Shutdown with light.
- Low Oil Pressure Shutdown with startup lockout timer (TD1) and light.