

# SERIES 210 STAINLESS STEEL GLOBE VALVE

M-000557  
RELEASED 7/2/91

SERVICE : 300#-720 PSI NON-SHOCK COLD
SERVICE : 150#-275 PSI NON-SHOCK COLD
TEMPERATURE RATING +100° F TO -325° F

UNLESS OTHERWISE SPECIFIED, VALVES NOT CLEANED FOR OXYGEN SERVICE

1	SET SCREW	300 SERIES STAINLESS STEEL
2	HANDWHEEL	MALLEABLE IRON
3	YOKE BUSHING	NAVAL BRASS
4	STEM	304 SERIES STAINLESS STEEL
5	YOKE	ST. STL. ASTM A-351 GRADE CF8
6	GLAND FLANGE	ST. STL. ASTM A-351 GRADE CF8
7	GLAND FLANGE SCREW	ST. STL. ASTM A-320-B8 CL. 1
8	GLAND FLANGE NUT	ST. STL. ASTM A-194-8
9	PACKING ADAPTER	NAVAL BRASS
10	STEM PACKING SET	PTFE
11	CHEVRON ADAPTER	300 SERIES STAINLESS STEEL
12	EXTENSION TUBE	304 SERIES STAINLESS STEEL
13	BONNET	ST. STL. ASTM A-351 GRADE CF8
14	STEM BEARING	BRONZE
15	BONNET BOLTS	ST. STL. ASTM A-320-B8 CL. 1
16	RETAINING RING	BERYLLIUM COPPER
17	BONNET NUTS *	ST. STL. ASTM A-194-8
18	DISC NUT	300 SERIES STAINLESS STEEL
19	DISC	300 SERIES STAINLESS STEEL
20	SEAT	PCTFE
21	SEAT RETAINER	300 SERIES STAINLESS STEEL
22	BODY	ST. STL. ASTM A-351 GRADE CF8
23	GASKET	25% GLASS FILLED PTFE
24	HANDWHEEL NUT	CADMIUM PLATED STEEL
25	WASHER	300 SERIES STAINLESS STEEL

\* NOT REQUIRED ON 1" & SMALLER VALVES

SIZE	"E"	"F"
1/2	.855	3/8
3/4	1.065	1/2
1	1.330	1/2
1 1/2	1.915	1/2

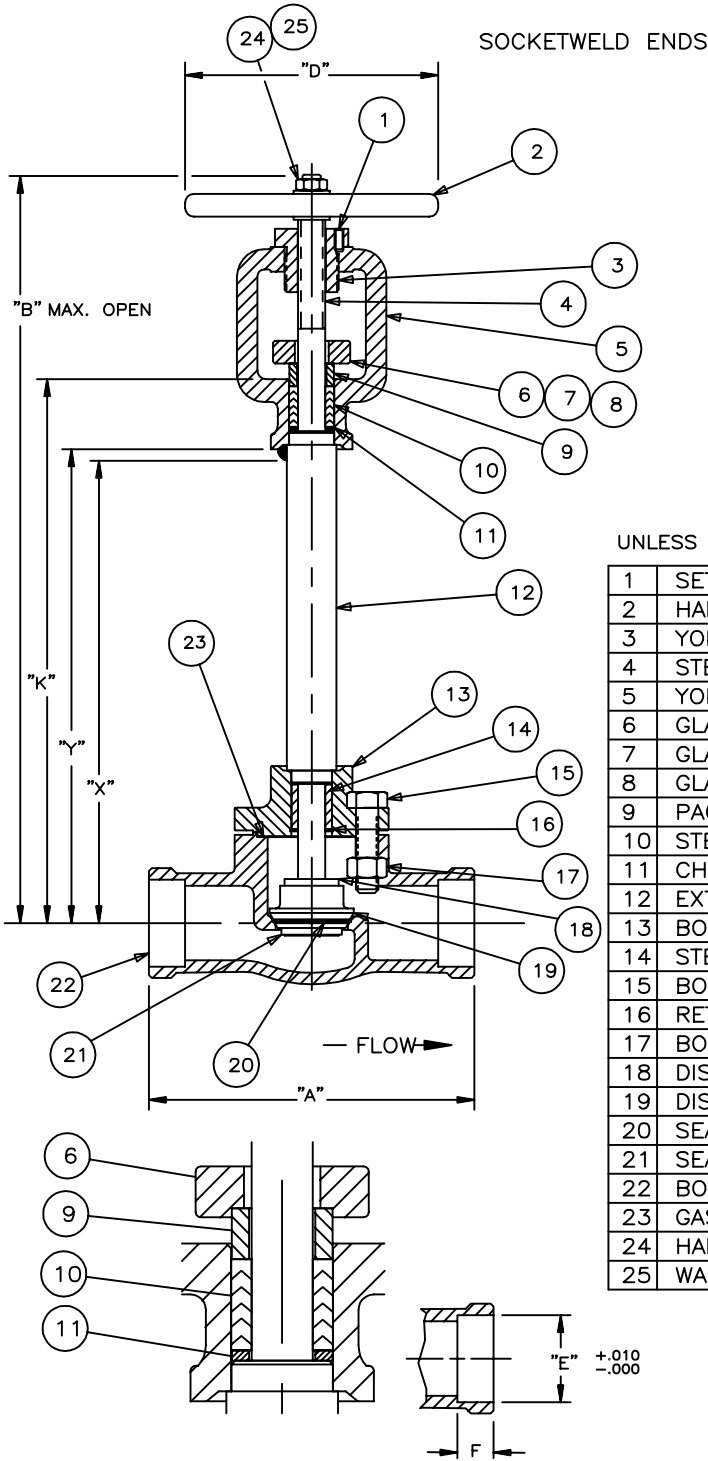

K,X & Y DIMENSIONS SHOWN ARE APPROXIMATE  
SPECIAL B,K,X & Y DIMENSIONS ARE AVAILABLE  
ALL INFORMATION IS SUBJECT TO LATEST REVISION

ALL DIMENSIONS ARE IN INCHES

SIZE	"A"	"B"	"D"	"K"	"X"	"Y"
1/2	5	18 1/8	5	12 3/4	11 1/16	11 3/8
3/4	5	18 1/8	5	12 3/4	11 1/16	11 3/8
1	5	18 1/8	5	12 3/4	11 1/16	11 3/8
1 1/2	10 1/4	22 1/4	7	15	12 3/4	13 1/16

GODDARD VALVE CORPORATION 705 PLANTATION STREET WORCESTER, MA. 01605  
TEL: (508) 852-2435 E-MAIL: valve@goddardvalve.com FAX: (508) 852-2443