

tyco

Cash Valve

**CRYOGENIC
CONTROLS**

ISSUED - FEBRUARY 2000
CAVMC-0514-US-0208
ISO 9001 Certified

A WORD ABOUT CRYOGENICS...

Cryogenics — the science of materials at extremely low temperatures — has become more and more important to industry. One important aspect of this field is the liquification of normally gaseous elements, including the following, which are widely used throughout industry:

OXYGEN - Used extensively in BOF furnaces in the steel industry, for metal cutting, as a rocket fuel and in medicine.

ACETYLENE - Widely used in welding.

NITROGEN - Used in refrigeration systems, for metal degassing, in aerosol packaging and in cryogenic surgery.

HYDROGEN - Used as a rocket propellant and in the production of several metals.

ARGON - Widely used in incandescent lamps and fluorescent tubes.

HELIUM - Used for arc welding, in the manufacture of electron tubes and in cryogenic research.

CARBON DIOXIDE - Used in refrigeration, to make aerosol tanks and in fire fighting.

Other cryogenic fluids include liquefied natural gas, fluorine, krypton, neon, methane and ethane.

Industrial gases were previously stored in large, bulky, pressurized metal containers, but now these gases are stored and shipped in their liquid state in cryogenic containers called “Dewars” or converters. Dewars are jacketed storage vessels that safely maintain liquids at cryogenic temperatures. The main advantage of cryogenic containers is a substantial saving of storage space as demonstrated by the following example: 162.8 standard cubic feet (4.61 cubic meters) of gas at ambient temperature, when subjected to a pressure of 2,400 psi (168.72 kg/sq cm) in a pressurized container, will have a measured volume of one cubic foot (.028 cubic meter); however, 696 standard cubic feet (19.1 cubic meters) of the same gas can be stored in its liquid state at cryogenic temperatures in a Dewar with the same measured volume of one cubic foot (.028 cubic meter). This means that, under cryogenic conditions, the Dewar can accommodate 4.28 times the quantity of a normally gaseous element as a pressurized gas cylinder.

Cryogenic converters are available in a variety of sizes and shapes and can be either stationary or installed on over-the-road transport trucks. They are generally used for liquids with a boiling point anywhere from -109.3°F (194.7°K) for carbon dioxide to -452°F (4.3°K) for helium. Dewars are supplied with inbuilt controls that allow the material to be drawn as either liquid or gas. The schematic located on the back cover illustrates a typical cryogenic container and controls. While there are many different versions of this basic system, the components remain fairly constant. Cash Valve manufactures a variety of controls for cryogenic systems, including liquid and gas line-pressure build-up regulators, economizer (heat leak) back-pressure valves, temperature safety valves, combination valves, shut-off valves and final-line/service-line regulators. This data sheet presents a detailed description of Cash Valve’s line of cryogenic-service valves.

THE PRESSURE BUILD-UP CIRCUIT

The purpose of the build-up circuit is to maintain in the converter a pressure approximately 25 psi (1.76 kg/sq cm) above that required to drive the liquid to the final vaporizer and to maintain a pressure differential of approximately 25 psi (1.76 kg/sq cm) or higher across the service line regulator. To do this, liquid is drawn into the pressure build-up coil, where it is warmed by ambient air and vaporized. The gas then passes through the pressure build-up regulator and into the top of the tank, where it begins to build up pressure because expansion is limited by the fixed volume. When this pressure reaches the set point of the pressure build-up regulator, the regulator shuts off,

stopping vaporization and pressure build-up. As liquid is forced from the tank to the final vaporizer, pressure in the tank begins to drop and the pressure build-up regulator again begins operating.

The pressure build-up regulator may be located in the liquid line before the pressure build-up coil. Since it is now used for liquid rather than gas service, the regulator may have a smaller orifice or be a smaller-sized valve. The operation of a liquid pressure build-up regulator is the same as that of a gas regulator with the exception that it regulates the liquid flow before the pressure build-up coil rather than the

gas flow after the coil. When pressure in the tank drops, the liquid pressure build-up regulator opens, allowing liquid to flow through the pressure build-up coil and vaporize.

Cash Valve manufactures pressure build-up regulators for most cryogenic system applications. The Type A-32 is a small (1/4", 8mm) pressure build-up valve; the larger Type B, Type G-60 and Type E-55 can be used for either liquid or gas. The Type B is available in sizes from 1/4" through 2" (8mm through 50mm), the G-60 from 1/4" through 1 1/2" (8mm through 40mm) and the Type E-55 from 1 1/4" through 2" (32mm through 50mm).

PRESSURE REDUCING VALVES/PRESSURE BUILD-UP REGULATORS

A-32 PRESSURE REDUCING OR PRESSURE BUILD-UP SERVICE

CONSTRUCTION

Brass forged body and spring chamber; bronze trim and diaphragms; Teflon® seat disc and diaphragm gasket; stainless steel pressure spring. All parts are commercially cleaned for cryogenic service.

NOTE: Also available in stainless steel and special construction for Hi-Purity service. Consult the factory.

TEMPERATURE RATING

+150°F (339°K) to -320°F (78°K)

MAXIMUM INITIAL PRESSURE

600 psi (42.18 kg/sq cm)

REDUCED PRESSURE RANGES

SPRING NUMBER	MAXIMUM WORKING PRESSURE	
	PSI	KG/SQ CM
4764	2-25	0.14-1.76
4765	15-65	1.05-4.57
12447	40-100	2.81-7.03
12108	50-150	3.52-10.55
7337	75-175	5.27-12.30
10661	100-250	7.03-17.58
—	200-400	14.06-28.12
—	300-600	21.09-42.18

DIMENSIONS

SIZE		DIMENSIONS				SHIPPING WEIGHT			
INCHES	MM	A INCHES	MM	B INCHES	MM	C INCHES	MM	LBS	KGS
1/4	8	2 1/4	57.15	3 3/16	80.96	5/8	15.88	1 1/8	0.51
3/8	10	2 1/4	57.15	3 3/16	80.96	5/8	15.88	1 1/8	0.51

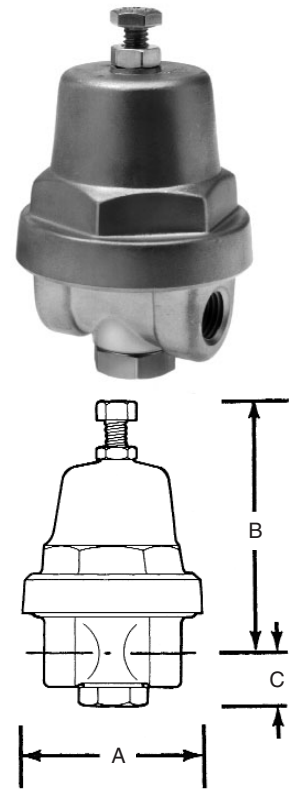

A-36 PRESSURE REDUCING OR PRESSURE BUILD-UP SERVICE

CONSTRUCTION

Brass forged body and bronze spring chamber; bronze trim and diaphragms; Teflon® seat disc and gaskets; stainless steel pressure spring. All parts are commercially cleaned for cryogenic service.

NOTE: Also available in stainless steel and special construction for Hi-Purity service. Consult the factory.

TEMPERATURE RATING

+150°F (339°K) to -320°F (78°K)

MAXIMUM INITIAL PRESSURE

400 psi (28.12 kg/sq cm)

REDUCED PRESSURE RANGES

VALVE NUMBER	SPRING NUMBER	MAXIMUM WORKING RANGES	
		PSI	KG/SQ CM
11520 only	8238	10-30	0.70-2.11
	8239	20-50	1.41-3.52
	8240	40-80	2.81-5.62
	8241	75-150	5.27-10.55
	8242	100-250	7.03-17.58
High Pressure Construction Only			
15299 only	14272	200-400	14.06-28.12

DIMENSIONS

VALVE NUMBER	SIZE	DIMENSIONS				SHIPPING WEIGHT			
		A INCHES	MM	B INCHES	MM	C INCHES	MM	LBS	KGS
11520	3/8 10	2 7/16	61.91	4 1/2	114.30	1	25.40	2 1/2	1.13
15299	3/8 10	2 7/16	61.91	4 1/2	114.30	1	25.40	2 1/2	1.13

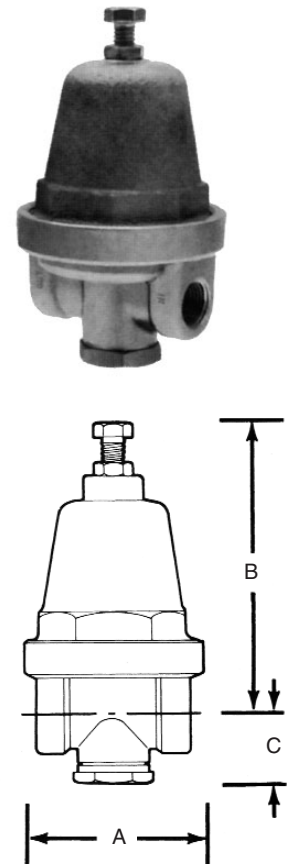

PRESSURE REDUCING VALVES/PRESSURE BUILD-UP REGULATORS

B PRESSURE REDUCING OR PRESSURE BUILD-UP SERVICE



CONSTRUCTION

Bronze body, spring chamber, trim and diaphragms; Teflon® seat and diaphragm gasket; stainless steel pressure spring; stainless steel bolts and nuts; Teflon® bottom-plug gasket; Monel® strainer screen. All parts are commercially cleaned for cryogenic service. Also available with BSP threads.

TEMPERATURE RATING

+150°F (339°K) to -320°F (78°K)

MAXIMUM INITIAL PRESSURE

400 psi (28.12 kg/sq cm)

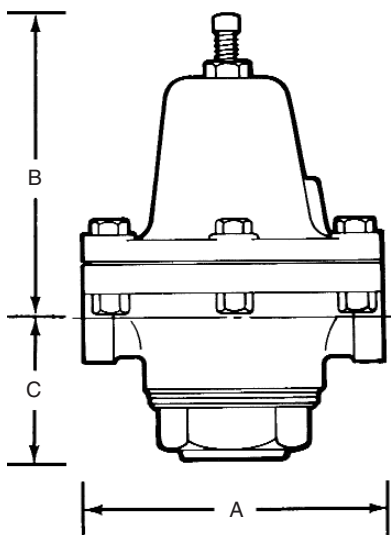

REDUCED PRESSURE RANGES					
VALVE SIZE	INCHES		SPRING NUMBER	MAXIMUM WORKING RANGES	
	INCHES	MM		psi	KG/SQ CM
1/4	8		4765	10-30	0.70-2.11
			7337	25-100	1.76-7.03
			8741	50-200	3.52-14.06
			10661	100-250	7.03-17.58
3/8	10		11143	10-50	0.70-3.52
			8691	40-150	2.81-10.55
			14301	100-250	7.03-17.58
			11143	10-30	0.70-2.11
1/2	15		10016	20-75	1.41-5.27
			10017	25-125	1.76-8.79
			10018	100-200	7.03-14.06
			10019	150-250	10.55-17.58
			11143	10-30	0.70-2.11
3/4	20		10016	20-70	1.41-4.92
			10017	30-100	2.11-7.03
			10018	50-150	3.52-10.55
			10019	100-225	7.03-15.82
			9983	150-250	10.55-17.58
1	25		8484	10-35	0.70-2.46
			8485	20-60	1.41-4.22
			8486	50-100	2.52-7.03
			8487	100-250	7.03-17.58
			8484	10-30	0.70-2.11
1 1/4	32		8485	20-40	1.41-2.81
			8486	35-80	2.46-5.62
			8487	75-150	3.52-10.55
			8484	10-30	0.70-2.11
1 1/2	40		8485	20-40	1.41-2.81
			8486	35-80	2.46-5.62
			8487	75-150	3.52-10.55
			6301	5-20	0.35-1.41
2	50		8773	10-50	0.70-3.52
			12913	20-100	1.41-7.03

DIMENSIONS

VALVE NUMBER	SIZE		DIMENSIONS						SHIPPING WEIGHT	
	INCHES	MM	A INCHES	A MM	B INCHES	B MM	C INCHES	C MM	LBS	KGS
12315	1/4	8	3	76.2	27/8	73.03	13/4	44.45	3	1.35
12316	3/8	10	37/8	98.43	41/8	104.78	13/4	44.45	5 1/2	2.47
12290	1/2	15	4 1/2	114.3	4 1/2	114.3	2 1/8	53.98	8	3.6
12300	3/4	20	5 1/8	130.18	4 5/8	117.48	2 1/8	53.98	10	4.5
12319	1	25	5 7/8	149.23	5 3/8	136.53	2 5/8	66.68	16	7.2
12320	1 1/4	32	6 3/4	171.45	6 1/8	155.58	2 5/8	66.68	20	9.0
12321	1 1/2	40	6 3/4	171.45	6 1/8	155.58	3 1/4	82.55	20	9.0
8580	2	50	9 1/4	234.95	8 1/2	215.9	3 1/2	88.90	37	16.65

G-60 PRESSURE REDUCING OR PRESSURE BUILD-UP SERVICE

CONSTRUCTION

Threaded ends; bronze body, spring chamber, diaphragms and trim; stainless steel pressure spring and body seat; Teflon® seat and gaskets; stainless steel bolts. Closing cap over screw provided. Also available with all system exposed internal parts in stainless steel. All parts are commercially cleaned for cryogenic service. Also available with BSP threads.

NOTE: Also available in stainless steel and special construction for Hi-Purity service. Consult the factory.

TEMPERATURE RATING

+150°F (339°K) to -320°F (78°K)

MAXIMUM INITIAL PRESSURE

600 psi (42.18 kg/sq cm)



Reduced Pressure Ranges				
VALVE SIZE		SPRING NUMBER	MAXIMUM WORKING RANGES	
INCHES	MM		psi	KG/SQ CM
1/4 & 3/8	8 & 10	8483	5-30	0.35-2.11
		8484	15-65	1.05-4.57
		8485	30-110	2.11-7.73
		8486	75-200	5.27-14.06
		10019*	100-400*	7.03-28.12*
		8487*	100-600*	7.03-42.18*
1/2	15	8488	0-7	0-0.49
		8489	5-70	0.35-4.92
		8490	50-150	3.52-10.55
		7806	50-250	3.52-17.58
		7806*	100-600*	7.03-42.18
3/4	20	8493	0-10	0-0.70
		8494	5-75	0.35-5.27
		8495	50-200	3.52-14.06
1	25	8495*	100-600*	7.03-42.18
		10672	10-50	0.70-3.52
		10751	50-200	3.52-14.06
1 1/4 & 1 1/2	32 & 40	10751*	100-600*	7.03-42.18
		13577	5-15	0.35-1.05
		13579	10-50	0.70-3.52
		13581	30-75	2.11-5.27
		13583	50-120	3.52-8.44
		13575	75-150	5.27-10.55
		13575*	100-400*	7.03-28.12

* Note: Higher ranges are attained by modifying standard valve and/or using a different pressure spring. Consult the factory.

Dimensions									
SIZE	A		B		C		SHIPPING WEIGHT		
	INCHES	MM	INCHES	MM	INCHES	MM	LBS	KGS	
1/4	8	4	101.60	6 ⁵ / ₈	168.28	2 ³ / ₁₆	55.55	9	4.05
3/8	10	4	101.60	6 ⁵ / ₈	168.28	2 ³ / ₁₆	55.55	9	4.05
1/2	15	4 ³ / ₄	120.65	7 ⁵ / ₈	193.68	2 ⁵ / ₁₆	58.72	16	7.20
3/4	20	5 ⁵ / ₈	142.88	10	254.00	2 ⁵ / ₈	66.68	24	10.80
1	25	6 ¹ / ₂	165.10	10 ³ / ₄	273.05	2 ⁷ / ₈	73.03	35	15.75
1 1/4	32	8	203.20	12 ⁵ / ₁₆	312.74	3 ⁹ / ₁₆	90.49	63	28.35
1 1/2	40	8	203.20	12 ⁵ / ₁₆	312.74	3 ⁹ / ₁₆	90.49	63	28.35

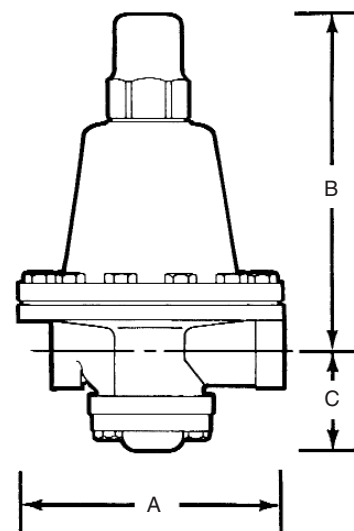

E-55 PRESSURE REDUCING OR PRESSURE BUILD-UP SERVICE



CONSTRUCTION

Bronze body, spring chamber, trim; stainless steel body seat and pressure spring; Teflon® seat, O-rings, and bottom plug gasket; Monel® diaphragms and strainer screen; stainless steel bolts. All parts are commercially cleaned for cryogenic service. Also available with BSP threads.

TEMPERATURE RATING

+150°F (339°K) to -320°F (78°K)

MAXIMUM INITIAL PRESSURE

400 psi (28.12 kg/sq cm)

REDUCED PRESSURE RANGES

VALVE SIZE	SPRING NUMBER	MAXIMUM WORKING RANGES	
		psi	KG/SQ CM
All Sizes	8773	20-70	1.41-4.92
	12913	50-150	3.52-10.55
	8774	75-300	7.03-17.58

DIMENSIONS

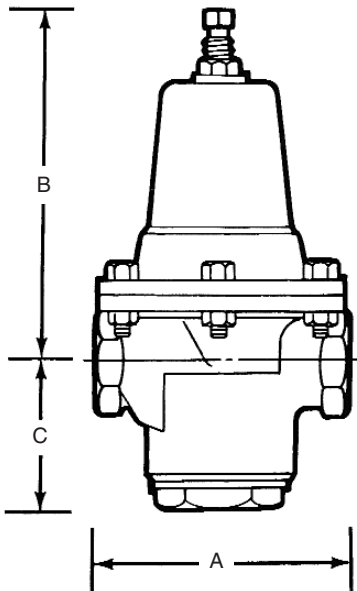

VALVE NUMBER	SIZE		DIMENSIONS						SHIPPING WEIGHT	
	INCHES	MM	A INCHES	A MM	B INCHES	B MM	C INCHES	C MM	LBS	KGS
11980	1 1/4	32	5 5/8	142.88	7 7/8	200.0	3 1/4	82.55	17	7.65
11981	1 1/2	40	5 5/8	142.88	7 7/8	200.0	3 1/4	82.55	17	7.65
11982	2	50	5 3/4	146.05	8 1/2	215.9	2 7/8	73.03	17	7.65

THE ECONOMIZER CIRCUIT

The Economizer Back Pressure Regulator is set from 10 to 25 psi (.70 to 1.76 kg/sq cm) above the set pressure of the pressure build-up regulator. When no gas is being used and heat leakage in the tank causes a gas pressure build-up, the excess pressure is bypassed into the final

vaporizer line to conserve gas rather than allow the safety valve in the pressure build-up circuit to relieve the excess gas into the atmosphere.

Cash Valve offers five types of back pressure valves for this circuit: the Type FRM, low flows, max. 600 psi (42.18 kg/sq cm), the FRM-2, medium flows,

max. 250 psi (17.58 kg/sq cm), the FRM-2 High Pressure, medium flows, max. 400 psi (28.12 kg/sq cm), the FR, large flows, max. 400 psi (28.12 kg/sq cm), and the FR-6, max. 600 psi (42.18 kg/sq cm).

FRM BACK PRESSURE OR ECONOMIZER SERVICE

CONSTRUCTION

Threaded ends; 2-way, side inlet-side outlet; 2-way, side inlet-bottom outlet; 3-way, 2 side inlets-bottom outlet; forged bronze body; bronze diaphragms; stainless steel seat disc, seat ring and pressure spring; Teflon® diaphragm gasket. All parts commercially cleaned for cryogenic service.

NOTE: Also available in stainless steel and special construction for Hi-Purity service. Consult the factory.

TEMPERATURE RATING
+150°F (339°K) to -320°F (78°K)

MAXIMUM SET PRESSURE
600 psi (42.18 kg/sq cm)



PRESSURE RANGES

SPRING NUMBER	MAXIMUM WORKING RANGES	
	PSI	KG/SQ CM
4764	2-25	0.14-1.76
4765	15-65	1.05-4.57
12447	40-100	2.81-7.03
7337	75-175	5.27-12.30
10661	100-250	7.03-17.58
—	200-400	14.06-28.12
—	300-600	21.09-42.18

DIMENSIONS

VALVE NUMBER*	DESCRIPTION	SIZE		SHIPPING WEIGHT	
		INCHES	MM	LBS	KGS
11224	Side inlet, Side outlet	1/4	8	1 1/8	0.51
11225	Side inlet, Side outlet	3/8	10	1 1/8	0.51
7335	Side inlet, Bottom outlet	1/4	8	1 1/8	0.51
9172	Side inlet, Bottom outlet	3/8	10	1 1/8	0.51
8250	2 Side inlets, Bottom outlet	1/4	8	1 1/8	0.51

* Use valve numbers for pressures to 175 psi only. Consult factory for other numbers.

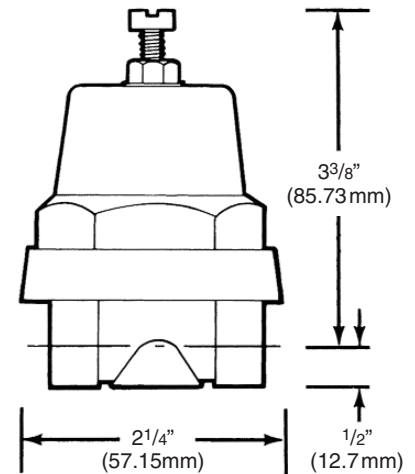

BACK PRESSURE/ECONOMIZER VALVES



FRM-2, FRM-2 (HP) BACK PRESSURE OR ECONOMIZER SERVICE

CONSTRUCTION

Threaded ends; 2-way, side inlet-side outlet; 2-way, side inlet-bottom outlet; 3-way, 2 side inlets-bottom outlet; forged bronze body; cast bronze spring chamber; stainless steel seat disc, seat ring and pressure spring; bronze diaphragms; Teflon® diaphragm gasket. All parts commercially cleaned for cryogenic service.

NOTE: FRM-2 available in stainless steel and special construction for Hi-Purity service. Consult the factory.

TEMPERATURE RATING

+150°F (339°K) to -320°F (78°K)

MAXIMUM SET PRESSURE

FRM-2: 250 psi (17.58 kg/sq cm)

FRM-2HP: 400 psi (28.12 kg/sq cm)

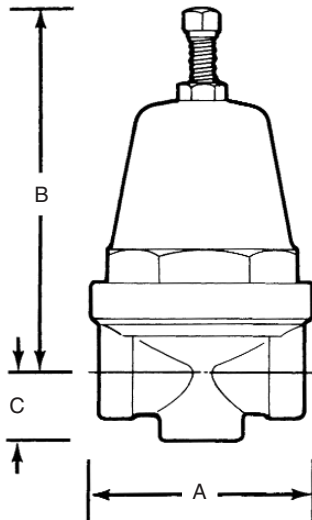

PRESSURE RANGES

SPRING NUMBER	SIZE	MAXIMUM WORKING RANGES psi	KG/SQ CM
FRM-2			
8238	All Sizes	0-30	0-2.11
8239	All Sizes	20-50	1.41-3.52
8240	All Sizes	40-80	2.81-5.62
8241	All Sizes	75-150	5.27-10.55
8242	All Sizes	100-275	7.03-19.34
FRM-2HP			
14272	All Sizes	200-400	14.06-28.12

DIMENSIONS

VALVE NUMBER*	DESCRIPTION	SIZE		A		DIMENSIONS B		C		SHIPPING WEIGHT	
		INCHES	MM	INCHES	MM	INCHES	MM	INCHES	MM	LBS	KGS
FRM-2											
12790	Side inlet, Side outlet	1/4	8	21 ¹¹ / ₁₆	68.26	4 1/2	114.3	3/4	19.05	2 1/2	1.13
11831	Side inlet, Side outlet	3/8	10	21 ¹¹ / ₁₆	68.26	4 1/2	114.3	3/4	19.05	2 1/2	1.13
10673	Side inlet, Side outlet	1/2	15	27 ⁷ / ₈	73.03	4 1/2	114.3	1 1/8	28.58	3 1/2	1.58
8702	Side inlet, Bottom outlet	1/4	8	21 ¹¹ / ₁₆	68.26	4 1/2	114.3	3/4	19.05	2 1/2	1.13
8703	Side inlet, Bottom outlet	3/8	10	21 ¹¹ / ₁₆	68.26	4 1/2	114.3	3/4	19.05	2 1/2	1.13
8704	Side inlet, Bottom outlet	1/2	15	27 ⁷ / ₈	73.03	4 1/2	114.3	1 1/8	28.58	3 1/2	1.58
12605	2 Side inlets, Bottom outlet	1/4	8	21 ¹¹ / ₁₆	68.26	4 1/2	114.3	3/4	19.05	2 1/2	1.13
8245	2 Side inlets, Bottom outlet	3/8	10	21 ¹¹ / ₁₆	68.26	4 1/2	114.3	3/4	19.05	2 1/2	1.13
12070	2 Side inlets, Bottom outlet	1/2	15	27 ⁷ / ₈	73.03	4 1/2	114.3	1 1/8	28.58	3 1/2	1.58
FRM-2HP											
14275	Side inlet, Side outlet	1/4	8	21 ¹¹ / ₁₆	68.26	4 1/2	114.3	25 ²⁵ / ₃₂	19.84	2 1/2	1.13
15555	Side inlet, Bottom outlet	1/4	8	21 ¹¹ / ₁₆	68.26	4 1/2	114.3	25 ²⁵ / ₃₂	19.84	2 1/2	1.13
15392	Side inlet, Side outlet	3/8	10	21 ¹¹ / ₁₆	68.26	4 1/2	114.3	25 ²⁵ / ₃₂	19.84	2 1/2	1.13
16719	Side inlet, Bottom outlet	3/8	10	21 ¹¹ / ₁₆	68.26	4 1/2	114.3	25 ²⁵ / ₃₂	19.84	2 1/2	1.13
15895	Side inlet, Side outlet	1/2	15	21 ¹¹ / ₁₆	68.26	4 1/2	114.3	1 1/8	28.585	3 1/2	1.58
15425	Side inlet, Bottom outlet	1/2	15	21 ¹¹ / ₁₆	68.26	4 1/2	114.3	25 ²⁵ / ₃₂	19.84	3 1/2	1.58

FR, FR-6 BACK PRESSURE OR ECONOMIZER SERVICE

CONSTRUCTION

Threaded ends; 3-way, 2 side inlets-bottom outlet; bronze body, spring chamber and diaphragms; brass body seat; stainless steel seat disc, seat ring and pressure spring; Teflon® O-ring and diaphragm gasket; stainless steel bolts; pressure-tight closing cap. All parts are commercially cleaned for cryogenic service. Also available with BSP threads.

NOTE: Also available in stainless steel and special construction for Hi-Purity systems. Consult the factory.

TEMPERATURE RATING

+150°F (339°K) to -320°F (78°K)

MAXIMUM INITIAL PRESSURE

Type FR: 250 psi (17.58 kg/sq cm)
 Type FR-6: 400 psi (28.12 kg/sq cm)
 600 psi (42.18 kg/sq cm) on 1/2"

MAXIMUM SET PRESSURE

See pressure range chart below. For higher pressure, consult the factory.

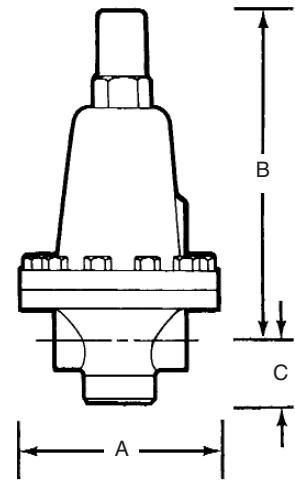

DIMENSIONS

FR-6 VALVE NO.	FR VALVE NO.	SIZE		A		B		C		SHIPPING WEIGHT	
		IN.	MM	IN.	MM	IN.	MM	IN.	MM	LBS	KGS
	13782	1/2	15	4 ³ / ₄	120.65	6 ³ / ₄	171.45	1 ⁵ / ₈	41.28	9 ¹ / ₂	4.27
16360	13784	3/4	20	5 ⁵ / ₈	142.88	8	203.20	2	50.80	14 ³ / ₄	6.64
15897	13785	1	25	6 ¹ / ₂	165.1	10 ⁵ / ₁₆	261.94	2 ¹ / ₄	57.15	23 ¹ / ₂	10.58
16361	13786	1 ¹ / ₄	32	6 ¹ / ₂	165.1	10 ⁷ / ₈	276.23	2 ³ / ₈	60.33	24 ¹ / ₂	11.03
16362	13789	1 ¹ / ₂	40	7 ¹ / ₂	190.5	10 ³ / ₄	273.05	2 ⁵ / ₈	66.68	33	14.85
16363	13790	2	50	7 ¹ / ₂	190.5	11	279.40	2 ⁵ / ₈	66.68	35 ¹ / ₂	15.98

PRESSURE RANGES

VALVE SIZE RANGES		SPRING	MAX. WORKING		VALVE SIZE RANGES		SPRING	MAX. WORKING	
INCHES	MM	NUMBER	psi	KG/SQ CM	INCHES	MM	NUMBER	psi	KG/SQ CM
1/2	15	8483	0-20	0-1.41	1 ¹ / ₄	15	8493	0-15	0-1.06
		8484	10-50	0.70-3.52			8494	20-85	1.41-5.98
		8485	40-90	2.81-6.33			6964	40-125	2.81-8.79
		8486	75-200	5.27-14.06			8495	50-250	3.52-17.58
		8487	100-400	7.03-28.12			8495*	200-400*	14.06-28.12*
		8487*	300-600	21.09-42.18					
3/4	20	8488	0-10	0-.70	1 ¹ / ₂	40	8493	0-15	0-1.06
		8489	10-70	0.70-4.92			8494	10-55	0.70-3.87
		8490	50-175	3.52-12.30			6964	30-100	2.11-7.03
		7806	100-265	7.03-18.63			8495	40-160	2.81-11.25
		7806*	200-400*	14.06-28.12*			14300	100-250	7.03-17.58
				14300*	200-400*	14.06-28.12*			
1	25	8493	0-15	0-1.06	2	50	8493	0-15	0-1.06
		8494	20-75	1.41-5.27			8494	10-55	0.70-3.87
		6964	40-200	2.81-14.06			6964	30-100	2.11-7.03
		8495	50-250	3.51-17.58			8495	40-160	2.81-11.25
		8495*	200-400*	14.06-28.12*			14300	100-250	7.03-17.58
				14300*	200-400*	14.06-28.12*			

* NOTE: Requires special diaphragm ring and pressure plate.

COMBINATION PRESSURE BUILDER-ECONOMIZER

The new PBE Series regulators combine the pressure building and economizer functions into one unit. In the smaller PBE-1, the economizer function starts before the pressure build function stops. However, a

restriction orifice limits the economizer output, to prevent it from overpowering the pressure build function.

In the larger PBE-2, the economizer phase starts at the point at which the

pressure build level is reached, thus assuring a smooth transition between the two functions. For sizing information, request engineering data sheets 1074 (PBE-1) and 1077 (PBE-2).

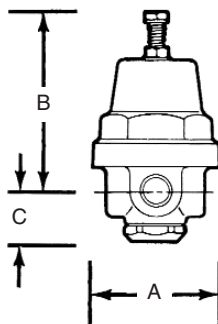

PBE1 COMBINATION PRESSURE BUILDER-ECONOMIZER

CONSTRUCTION

Forged brass body and spring chamber; brass and stainless steel trim. Teflon®/Armalon or bronze diaphragm. Stainless steel pressure spring. All parts are commercially cleaned for oxygen service.

TEMPERATURE RATING

+150°F (339°K) to -320°F (78°K)

MAXIMUM INITIAL PRESSURE

400 psi (28.12 kg/sq cm)

PRESSURE RANGES

SPRING PRESSURE NUMBER	MAX. WORKING	
	psi	KG/SQ CM
7337	50-175	3.52-12.32
19295	150-350	10.55-24.61
Other ranges		Consult Factory

DIMENSIONS

VALVE NUMBER	SIZE INCHES MM	A		DIMENSIONS B		C		SHIPPING WEIGHT	
		INCHES	MM	INCHES	MM	INCHES	MM	LBS	KG
19264	1/4 8	2 1/4	57.15	3 1/8	79.38	7/8	22.29	1.4	0.65
19276	Low Pressure - Ranges to 175 psig								
	High Pressure - Ranges 150 - 350 psig								

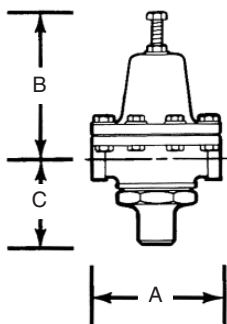

PBE2 COMBINATION PRESSURE BUILDER-ECONOMIZER

CONSTRUCTION

Bronze body, spring chamber, trim and diaphragms. Teflon® seat and diaphragm gasket. Stainless steel economizer seat. Stainless steel spring, nuts and bolts. All parts are commercially cleaned for oxygen service.

TEMPERATURE RATING

+150°F (339°K) to -320°F (78°K)

MAXIMUM INITIAL PRESSURE

400 psi (28.12 kg/sq cm)

PRESSURE RANGES

SPRING PRESSURE NUMBER	MAX. WORKING	
	psi	KG/SQ CM
11143	10-30	0.70-2.11
10016	20-75	1.41-5.27
10017	25-125	1.76-8.79
10018	100-200	7.03-14.06
10019	150-250	10.55-17.58

DIMENSIONS

VALVE NUMBER	SIZE INCHES MM	A		DIMENSIONS B		C		SHIPPING WEIGHT	
		INCHES	MM	INCHES	MM	INCHES	MM	LBS	KG
19405	1/2 15	4 1/2	114.30	5 1/4	133.35	3	76.20	9	4.08

LOW TEMPERATURE CUT-OFF

The temperature control valve between the vaporizer and service line regulator is designed to shut off the gas flow if the gas temperature drops below a pre-determined point, usually -20°F (144.4°K). Such a temperature drop is often caused by a rapid or quick gas draw. If the temperature drops below the setting of the temperature control valve, the valve closes to prevent excessively cold gas from reaching the service end of the system.

In particular, the cold gas is prevented from contacting the final-line regulator, which is not constructed or intended for such low-temperature conditions. The valve automatically opens when gas temperature rises above the set point.

For low temperature cut-off, Cash Valve offers the Type LTC temperature control valve, a double-port valve with a range of 0°F to -40°F (255°K to 233°K). The Type LTC is subject to ambient

temperature under normal conditions; therefore, it will normally be in a wide-open position. A copper well is recommended for each installation; this allows the removal of the capillary bulb without depressurizing the system.

NOTE: Valve seat closure may take several seconds under normal operating conditions. In addition, Type LTC fails in the closed position.

LTC REVERSE-ACTING TEMPERATURE REGULATOR FOR CRYOGENIC SERVICE

CONSTRUCTION

Brass union ends; bronze body and trim; copper capillary armor and bellows; Teflon® gasket and packing; stainless steel spring; copper bulb and capillary. Copper bulb is 1/2" x 5.82" (15mm x 147.83mm). All parts are commercially cleaned for oxygen service. A copper well is available as an option and is recommended for each cryogenic application.

MAXIMUM OPERATING LIMITS

Operating temperature range is 0°F to -40°F (255°K to 233°K); standard setting is -20°F (244°K). Maximum temperature limit is 300°F (408°K); minimum temperature limit is -320°F (78°K). Maximum body pressure on all sizes is 400 psi (28.12 kg/sq cm); however, for proper operation, maximum pressure differentials as shown in the following table must be observed.

TYPE LTC MAXIMUM PRESSURE DIFFERENTIALS

VALVE SIZE		TEMPERATURE SETTING					
		0°F (255°K)		-20°F (244.4°K)		-40°F (233°K)	
INCHES	MM	psi	KG/SQ CM	psi	KG/SQ CM	psi	KG/SQ CM
1/2-3/4	15-20	400	28.12	400	28.12	400	28.12
1	25	275	19.23	400	28.12	400	28.12
1 1/4-1 1/2	32-40	275	19.23	350	24.61	350	24.61
2	50	275	19.23	275	19.23	300	21.09

NOTE: It requires approximately 15°F change in temperature to fully close valve.

DIMENSIONS

VALVE NUMBER	SIZE IN.	SIZE MM	DIMENSIONS									
			A IN.	A MM	B IN.	B MM	C IN.	C MM	D IN.	D MM	E IN.	E MM
18131	1/2	15	6.04	153.42	2.08	52.84	9.80	248.92	4.31	109.48	2.50	63.50
18127	3/4	20	6.04	153.42	2.08	52.84	9.80	248.92	4.31	109.48	2.50	63.50
18112	1	25	6.04	153.42	2.08	52.84	9.80	248.92	4.31	109.48	2.50	63.50
18108	1 1/4	32	7.61	193.30	2.75	69.85	10.47	265.94	4.31	109.48	3.56	90.43
18042	1 1/2	40	7.61	193.30	2.75	69.85	10.47	265.94	4.31	109.48	3.56	90.43
18178	2	50	8.58	217.43	3.12	79.25	10.84	275.34	4.31	109.48	4.31	109.48

NOTE: Also available: Separable well - ask for part number 17960.
Thermal system repair kit - ask for part number 18052.

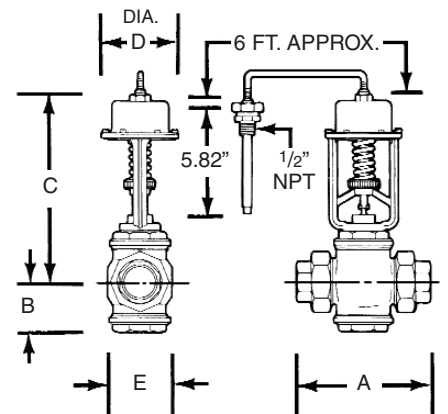

Continued on next page >

LOW TEMPERATURE CUT-OFF VALVES

TYPE LTC CAPACITY INFORMATION (SCFH) OXYGEN SERVICE – 50 PSI AND 100 psi LEVELS

SIZE	C _V	50 psi LEVEL				100 psi LEVEL			
		1 PSID	2 PSID	5 PSID	10 PSID	1 PSID	2 PSID	5 PSID	10 PSID
1/2"	9.0	4109	5788	9044	12530	5480	7734	12147	16986
3/4"	9.0	4109	5788	9044	12530	5480	7734	12147	16986
1"	13.0	5935	8361	13064	18100	7916	11171	17546	24535
1 1/4"	37.5	17122	24119	37684	52211	22835	32223	50612	70775
1 1/2"	37.5	17122	24119	37684	52211	22835	32223	50612	70775
2"	52.5	23970	33767	52757	73095	31969	45113	70857	99085

TYPE LTC CAPACITY INFORMATION (SCFH) OXYGEN SERVICE – 150 psi AND 200 psi LEVELS

SIZE	C _V	150 psi LEVEL				200 psi LEVEL			
		1 PSID	2 PSID	5 PSID	10 PSID	1 PSID	2 PSID	5 PSID	10 PSID
1/2"	9.0	6572	9280	14605	20495	7506	10602	16705	23485
3/4"	9.0	6572	9280	14605	20495	7506	10602	16705	23485
1"	13.0	9492	13404	21096	29603	10842	15315	24129	33922
1 1/4"	37.5	27382	38665	60853	85394	31274	44177	69604	97853
1 1/2"	37.5	27382	38665	60853	85394	31274	44177	69604	97853
2"	52.5	38334	54130	85195	119552	43784	61847	97445	136994

NOTE: psid values are pressure drops across valve.

TO DETERMINE CAPACITY

Determine operating pressure level at the valve and the maximum allowable pressure drop across the valve. Then refer to table above reading down the appropriate column to the selected pipe size. As an example: You are operating at a 150 psi pressure level and the maximum allowable pressure drop across the valve is 2 psi. You would look at the second table under

the 150 psi level and 2 psid column. For a 1 1/4" pipe size, the capacity would be 28,665 SCFH. Note: The values shown in the table are for oxygen gas; all capacity figures are

standard cubic feet per hour. To determine capacity figures for other gases, consult the conversion chart below and multiply the chart capacities by the factor given.

GAS CONVERSION FACTORS

GAS	OXYGEN	NITROGEN	HYDROGEN	HELIUM	ARGON
Factor	1.000	1.075	4.000	2.860	.893

FINAL LINE CIRCUIT (HOUSE LINE)

Liquid is forced into the vaporizer through the liquid line by the action of the vapor pressure in the tank. The liquid in the vaporizer is warmed by

ambient air (or sometimes by steam) and changed into gas, which is then distributed through the final-line regulator. Since the gas is at or near

ambient temperature, the diaphragm and seat in the regulator can be furnished in standard rubber materials.

A-31 PRESSURE REDUCING VALVE FOR FINAL-LINE GAS SERVICE

CONSTRUCTION

Brass forged body, brass piston. BUNA-N seat disc and diaphragm, aluminum spring chamber, stainless steel spring. All parts are commercially cleaned for oxygen service. Standard valve has side inlet-side outlet connections. Also available with side gauge connections.

TEMPERATURE RATING

+150°F (339°K) to 0°F (255°K)

MAXIMUM INITIAL PRESSURE

400 psi (28.12 kg/sq cm)



REDUCED PRESSURE RANGES

SPRING CHAMBER	MAXIMUM WORKING RANGES	
	psi	KG/SQ CM
4764	2-25	0.14-1.76
4765	15-65	1.05-4.57
12447	40-100	2.81-7.03
12108	50-150	3.52-10.55
7337	75-175	5.27-12.30

DIMENSIONS

VALVE NUMBER	SIZE INCHES	MM	DIMENSIONS				SHIPPING WEIGHT LBS	KGS		
			A INCHES	MM	B INCHES	MM			C INCHES	MM
14422	1/4	8	2 1/4	57.15	3 3/16	80.96	5/8	15.88	1 1/8	0.51

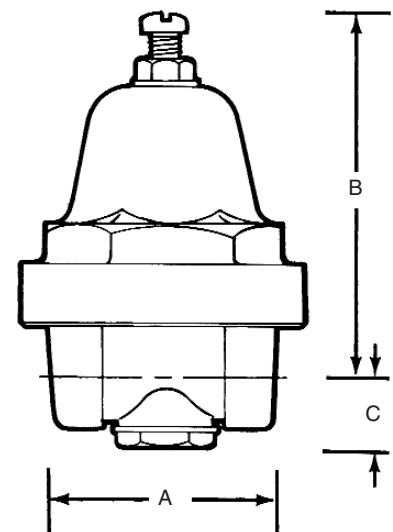

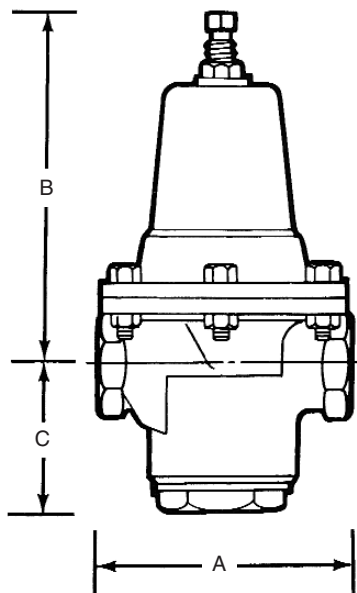

E-55 PRESSURE REDUCING VALVE FOR FINAL-LINE GAS SERVICE

CONSTRUCTION

Bronze body, spring chamber and trim; stainless steel body seat and pressure spring; Viton® seat disc, and Teflon® bottom plug gasket; Viton® O-ring and Neoprene diaphragm with Viton® liner; Monel® strainer screen. All parts are commercially cleaned for oxygen service. Also available with BSP threads.

TEMPERATURE RATING

+150°F (339°K) to 0°F (255°K)

MAXIMUM INITIAL PRESSURE

400 psi (28.12 kg/sq cm)

NOTE: Not for use on cold gas or liquid (less than 0°F). See E-55 (page 6) for pressure reducing or pressure build-up service.

REDUCED PRESSURE RANGES

VALVE SIZE INCHES	MM	SPRING NUMBER	MAXIMUM WORKING RANGES psi	KG/SQ CM
1/2", 3/4", 1"	15, 20, 25	8238	10-35	0.70-2.46
		8239	20-75	1.41-5.27
		8240	75-125	5.27-8.79
		8241	125-175	8.79-12.30
		8242	75-250	5.27-17.58
		8773	20-70	1.41-4.92
1 1/4", 1 1/2", 2"	32, 40, 50	12913	50-150	3.52-10.55
		8774	75-300	5.27-17.58

DIMENSIONS

VALVE NUMBER	SIZE INCHES	MM	A INCHES		B INCHES		C INCHES		SHIPPING WEIGHT LBSKGS	
			INCHES	MM	INCHES	MM	INCHES	MM		
18937	1/2	15	4	101.6	7 1/4	184.15	2 1/4	57.15	6	2.7
18938	3/4	20	4	101.6	7 1/4	184.15	2 1/4	57.15	6	2.7
18939	1	25	4	101.6	7 1/4	184.15	2 1/4	57.15	6	2.7
18940	1 1/4	32	5 5/8	142.88	11 1/8	282.58	3 1/4	82.55	17	7.7
18941	1 1/2	40	5 5/8	142.88	11 1/8	282.58	3 1/4	82.55	17	7.7
18942	2	50	5 3/4	146.05	11 3/8	288.93	2 7/8	73.03	17	7.7

HIGH PURITY REGULATING VALVES

Cash Valve also offers a line of high purity regulating valves for electronic grade and other high purity gases. This high purity line includes pressure reducing valves, back pressure valves and valves suitable for differential service.

Valve bodies are investment cast 316L stainless steel, with internal trim 316L bar stock. Interior (wetted) surface finish is 15 micro inch or better. The finish is electropolished. Also, all maintenance may be done without removing the valve from the line.

Sizes are 1/2" through 1 1/2", butt weld ends, 0.065 wall (1/2" size, 0.049 wall). Spring ranges are typically up to 400 psig control. Temperature limits are 400°F (478°K) to -425°F (19°K). All valves are cleaned for high purity gas compatibility.

Contact the factory or your Cash Valve representative for additional information and pricing.

Reference:

G60HP-Pressure Build Service
FRHP-Economizer Service



STRAINERS

Cash Valve bronze strainers are suited for most cryogenic applications. Installed in the line ahead of automatic regulators, they protect valve seats,

gauges, meters, regulators and other equipment from most foreign material to reduce maintenance costs and replacement expense.

SY-70C “Y” PATTERN STRAINERS

CONSTRUCTION

ASTM B62 high-tensile cast bronze body, 100 mesh Monel® strainer screen; a brass blowoff plug is shipped with each strainer. All parts are commercially cleaned for cryogenic service.

TEMPERATURE RATING

+150°F (339°K) to -320°F (78°K)

MAXIMUM SET PRESSURE

400 psi (28.12 kg/sq cm)



DIMENSIONS

STRAINER SIZE	BLOW OFF PLUG SIZE		DIMENSIONS				SHIPPING WEIGHT		
	INCHES	MM	INCHES	MM	A	B	LBS	KGS	
1/2	15	1/4	8	2 ¹⁵ / ₁₆	74.68	1 ²⁷ / ₃₂	46.99	0.6	0.27
3/4	20	1/4	8	3 ⁵ / ₈	91.95	1 ¹⁵ / ₁₆	49.53	1.3	0.59
1	25	3/8	10	4 ¹ / ₂	114.30	2 ³ / ₄	69.85	2	0.91
1 1/4	32	3/8	10	5 ¹ / ₈	130.30	3 ¹¹ / ₃₂	85.09	3.1	1.41
1 1/2	40	1/2	15	5 ¹³ / ₁₆	147.58	3 ³ / ₄	95.25	4.1	1.86
2*	50	3/4	20	6 ¹³ / ₁₆	172.58	4 ¹³ / ₁₆	122.68	9	4.08

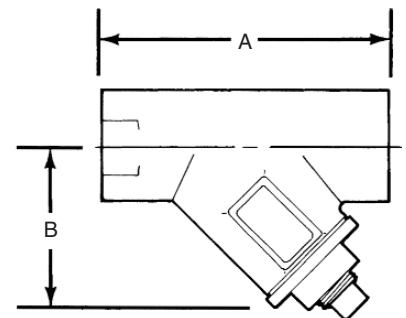

SAFETY RELIEF AND SHUT-OFF VALVES

Cash Valve also offers a line of cryogenic safety relief valves, the Type C-776. Available in sizes from 1/2" through 2". Request Data sheet CAVMC-0515 for details.



SYSTEM SCHEMATIC/HOW TO ORDER

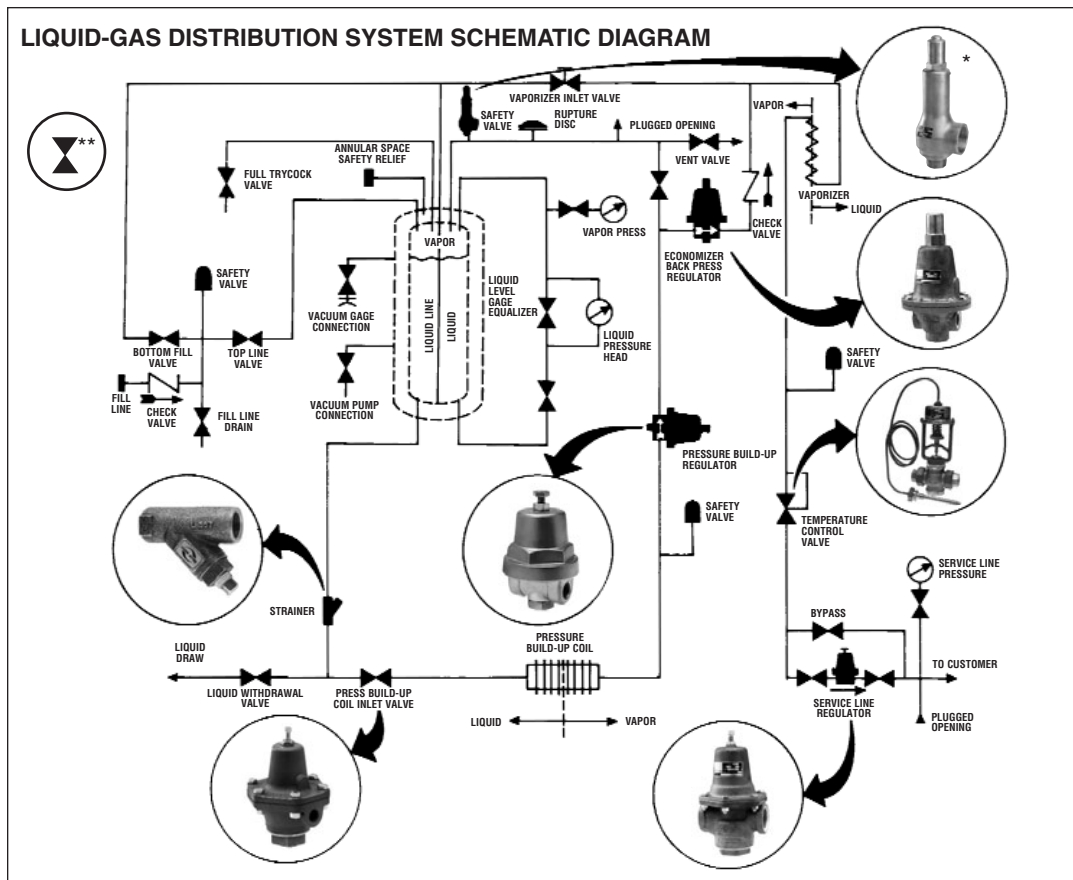

* C-776 Cryogenic safety relief valve - For additional information, write or call for data sheet CRY-C776.

** Shut-off valve - For additional information, see page 15.

HOW TO ORDER

Specify "Cash Valve regulator for cryogenic service" and the following:

1. Valve Type (A-31, A-32, A-36, B, E-55, FR, FRM, FRM-2, FRM-2 High Pressure, G-60, PBE-1, PBE-2, LTC, SY-70C)
2. Valve Size
3. Valve Number
4. Intended use:
Pressure build-up regulator, Back pressure (economizer) regulator, Low temperature cut-off, Final-line (house-line) regulator, Strainer

5. Service (liquid or gas)
6. Liquid or gas to be controlled
7. Set pressure
8. Range of pressure adjustment (or temperature adjustment for Type LTC)
9. Temperature

Also specify height of liquid column in cryogenic container.

CAPACITY INFORMATION:

Capacity information is available upon request. Write factory and supply the "how to order" information.

Cash Valve
953 Old U.S. Highway 70
Black Mountain, NC 28771
Phone: 800-879-2042 • 828-669-3710
Fax: 800-879-2057 • 828-669-0586
CAVMC-0514-US-0208

Tyco Valves & Controls
www.cashvalve.com