



0086

BS EN ISO 9001



FM 00707



Worcester Controls

*13/14 Series
3-Way Ball Valves*

FEATURES

- * Foolproof stem assembly to ball.
- * Mounting platform on valve body.
- * Wafer design.
- * Extensive range of seat materials.
- * Ball/seat design options.
- * Proven seat/seal design.

BENEFITS

- External indication of flow.
- Improved stem cycle life.
- Ease of maintenance.
- For greater pressure/temperature capability.
- Versatility to simplify process systems.
- For long life integrity.

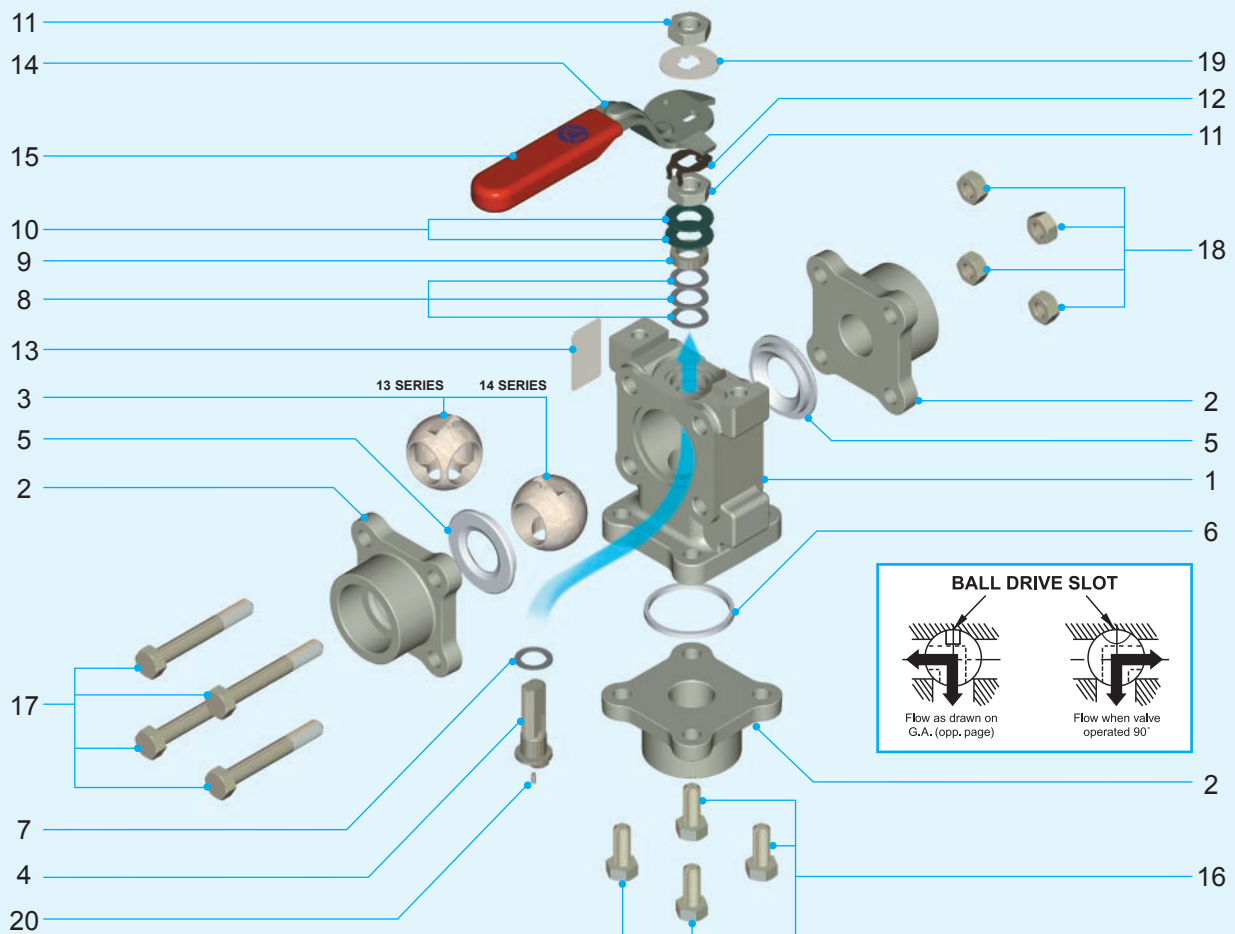

Note: Drawing shows bottom entry design with integral body seat/seal

PARTS/MATERIALS LIST

ITEM	DESCRIPTION	MATERIAL	ITEM	DESCRIPTION	MATERIAL
1.	Body	Stainless Steel ASTM A351 CF8M (UNS J92900) Carbon Steel ASTM A216 WCB (UNS J03002)	11.	Wrench / Gland Nut	Stainless Steel
2.	Body Connector	Stainless Steel ASTM A351 CF3M (UNS J92800) or ASTM A182 F316L (UNS S31603) or ASTM A351 CF8M (UNS J92900) Carbon Steel ASTM A105 (UNS K03504)	12.	Gland Nut Locking Clip	Carbon Spring Steel Rustproofed
3.	Ball	Stainless Steel ASTM A479 316 (UNS S31600)	13.	Identification Plate	Stainless Steel
4.	Stem	Stainless Steel AISI Type 316	14.	Wrench (See Note 3)	Carbon Steel Rustproofed / Stainless Steel
5.	Seat Ring / Seal	PTFE Virgin / 15% Glass Filled	15.	Wrench Sleeve	Vinyl Plastisol
6.	Body Connector Seal	PTFE Virgin	16.	Body Connector Screw	Carbon Steel Stainless Steel
7.	Stem Thrust Seal	PTFE 35% Carbon Filled	17.	Body Connector Bolt	Carbon Steel Stainless Steel
8.	Gland Packing	PTFE 35% Carbon Filled	18.	Body Connector Nut	Carbon Steel Stainless Steel
9.	Gland	Stainless Steel	19.	Flow Indicator	Stainless Steel
10.	Disc Spring	Stainless Steel	20.	Location Pin	Stainless Steel

The 13 and 14 Series were developed from Worcester's highly successful Series 44 three-piece ball valve in direct response to customer requirements to simplify process systems by replacing two valves with one.

The 13 and 14 Series comprises a number of variants which provide a range of operational solutions, as well as a variety of component materials for even greater flexibility.

OPERATION (13 and 14) The Series 13 requires a conventional 90° valve operation to change flow direction. However, during this operation all three ports are open and therefore mixing of media can occur.

The Series 14 requires a 180° operation to change flow direction and at 90° both ports are shut providing full isolation of the media. Mixing of the media will not occur during operation.

DIVERTER VALVES (D13 and D14) These are designed to divert media from the inlet port (side or bottom) to either of the two outlet ports. Standard Worcester seat/seal variants can be used with this design.

THREE WAY VALVES (T13 and T14) These valves use a combined seat and body seal enabling the valve to upstream seal and hold back media on one side of the valve whilst media flows through the other port. This provides greater application flexibility than the diverter valve.

PORTING CONFIGURATIONS The standard 13 and 14 Series have the third port on the bottom of the valve (identified with the letter A in the coding e.g. AD13). However the valves can be supplied with the third port on the side (SD13) but it should be noted that this option is only available with the Series 13 (90° operation).

VARIATIONS The 13 and 14 Series are available as full-bore using a B in the product coding e.g. BAT13. The valve can also be provided as firesafe (externally only) to BS6755 Part2.

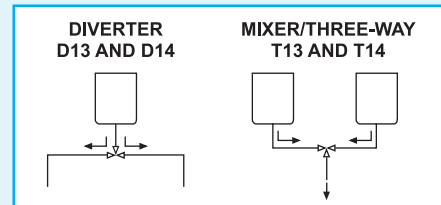

T13 VALVE

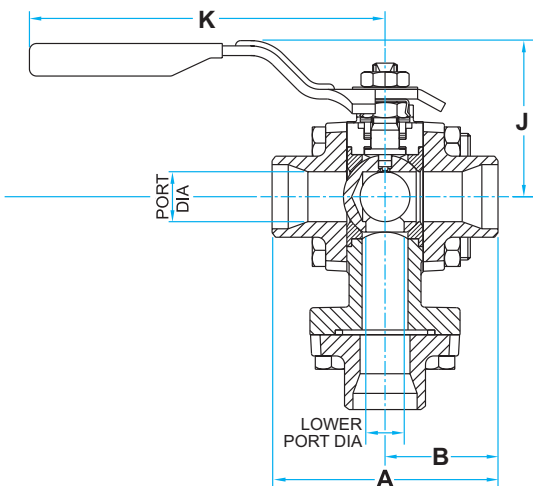
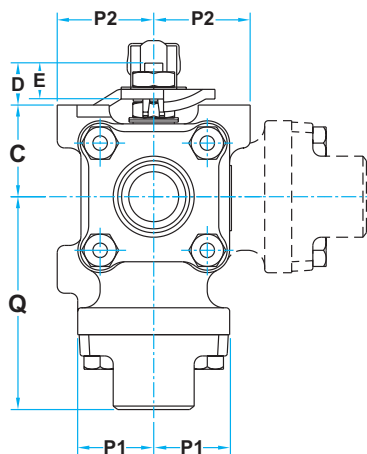
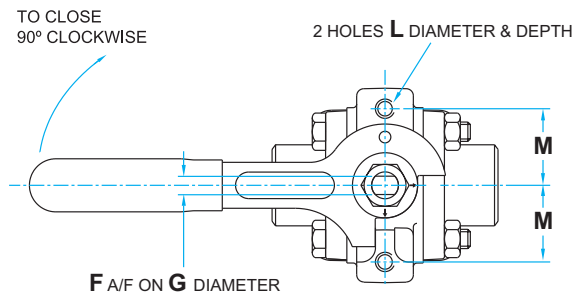
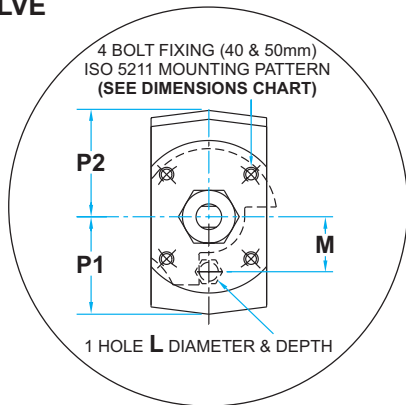

VALVE DIMENSIONS (mm)

Valve Size (mm)	Port Ø Min.	Lower Port Ø Min.	A	B	C	D	E	STEM		J	K	L THREAD & DEPTH	M	P1	P2	Q	MOUNTING PLATFORM (ISO 5211)			WEIGHT
								F A/F	G THREAD								ISO SIZE	MOUNTING HOLES	PLATFORM RECESS	
20	14.0	11.0	71.81 70.09	35.48	29.1 28.9	11.68 11.04	10.69 10.19	5.54 5.46	3/8"-24 UNF	60.3	136.0	M6 x1.0p 9.5 MIN	27.0	27.2	33.4	71.6 70.0				1.3
25	20.4	15.75	94.55 92.82	46.84	38.1 37.9	17.94 17.16	15.19 14.69	7.54 7.47	7/16"-20 UNF	64.8	149.0	M8 x1.25p 9.7 MIN	31.75	32.7	40.5	89.0 87.4				2.4
40	31.3	25.27	115.41 113.69	57.28	44.0 43.75	29.55 28.73	18.39 17.89	8.71 8.64	9/16"-18 UNF	77.9	181.0	M6 x1.0p 7.5 MIN	23.0	42.3	46.6	105.3 103.7	F05	4 OFF M6 x1.0p x8.7 DEEP MIN ON 50.0 P.C.D.	Ø 35.15/35.02 x4.01/3.26 DEEP	4.6
50	37.7	31.62	127.94 126.21	63.54	48.75 48.50	29.55 28.73	18.39 17.89	8.71 8.64	9/16"-18 UNF	82.6	181.0	M6 x1.0p 8.7 MIN	23.0	47.4	51.4	114.0 112.4	F05	4 OFF M6 x1.0p x8.7 DEEP MIN ON 50.0 P.C.D.	Ø 35.15/35.02 x4.01/3.26 DEEP	6.4

PRESSURE TEMPERATURE RATINGS

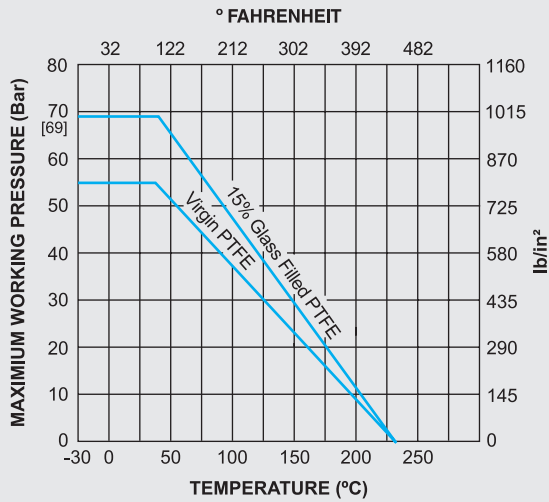

NOTES

1. Limiting stem input torque figures are based on random practical laboratory tests. For critical applications where a guaranteed figure is essential consult Worcester Controls.
2. Both 90° and 180° can be actuated pneumatically or electrically.
3. With 180° variant, a two piece wrench is required.
4. All weld end valves are assembled with Buna 'O' ring body connector seals with the correct body seals supplied loose.
5. Alternative seat/seal materials are available.
6. Installation, Operating and Maintenance Instructions are available on request.
7. Valves are reduced bore as standard. Full bore versions are also available.

FLOW COEFFICIENTS

Valve Size		Flow Coefficients	
mm	in	Cv	Kv
8-20	¼-¾	5	4
25	1	10	9
40	1½	24	21
50	2	36	31

Cv – Flow in US GPM Pressure – psi
Kv – Flow in M³/hr Pressure – bar

Due to continuous development of our product range, we reserve the right to alter the dimensions and information contained in this leaflet as required.

STANDARDS OF COMPLIANCE

Butt Weld Valves	Weld Preparation: SCH 40 & 10: BS 2633 suitable for Schedule Pipe to BS 1600
Socket Weld Valves	Prepared for assembly to plain end pipe in accordance with BS 1600
Screwed Valves	Thread Specification: BSP Taper - ISO/7 BS 21 BSP Parallel - BS 2779/ISO 228/1 ISO/7 (BS 21 DIN 2999) NPT- ANSI B1.20.1.
Test Rating	Valves are subjected to the requirements of BS 6755 for hydrostatic Shell test.

LIMITING STEM INPUT TORQUE

Valve Size		Limiting Stem Input Torque		See Note 2
mm	in	lbf/in	Nm	
8-20	¼-¾	117	13.2	
25-32	1¼	216	24.4	
40-50	1½-2	430	48.6	

How to order Worcester Valves and other Worcester products

Please order Worcester Valves and other products by description, not by part number.

We need a precise description of the valve you require. We will then translate this information into our own coding for order processing and production.

Please state the despatch address and desired date of delivery.



Side entry ST13 (l) mounted with Norbro 40R pneumatic actuator, and (r) T13 three-way valve with Norbro's Series 75 electric actuator.



Flowserve Flow Control (UK) Ltd
Burrell Road, Haywards Heath, West Sussex RH16 1TL
T: +44 (0)1444 314400 F: +44 (0)1444 314401
E-mail: wwukinfo@flowserve.com
Website: www.worcestercontrols.co.uk



Flow Control Division

TM indicates a trade mark of Worcester Controls Information given in this leaflet is made in good faith and based upon specific testing but does not, however, constitute a guarantee